

ONSCENE SOLUTIONS



PRODUCT CATALOG
PREMIUM CARGO SLIDES
LED LIGHTING
EQUIPMENT SECUREMENT

EFFECTIVE 2026



ON SCENE, FROM DAY 1.

For 20 years, we've been right beside you — teaming up to engineer only the best OnScene Solutions for your everyday scene. Our heavy-duty cargo slides, versatile LED lighting systems and in-compartment securement solutions are all designed to make your response swift and your crews safe.



ONSCENE SOLUTIONS

On scene at Texas A&M's training grounds

ORGANIZE FOR SUCCESS

ONSCENE SOLUTIONS CATALOG INDEX



HEAVY-DUTY SLIDES
PG 4-10

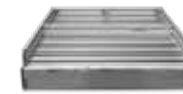

ADJUSTABLE TRAYS
PG 10



CARGO LIFT SYSTEMS
PG 11



LIGHTING SOLUTIONS
PG 12



EQUIPMENT SECUREMENT
PG 14

GET ORGANIZED AT ONSCENESOLUTIONS.COM



THE PREMIUM CARGO SLIDE.

Featuring the industry's only anodized aluminum cargo slides, OnScene Solutions builds the industry's most corrosion-resistant systems, backed by a lifetime warranty. And unlike our competitors who use metal rollers on metal glides, our Urethane wheels provide the smoothest gliding system on the market.

CORROSION-RESISTANT ANODIZED ALUMINUM
EASY-GLIDING URETHENE WHEELS
LARGE LATCH RELEASE DESIGNED FOR GLOVED HANDS
STANDARD LIFETIME WARRANTY



WHICH SLIDES ARE RIGHT FOR YOU? CHECK OUT OUR INSIDE FOLD SLIDE GUIDE.

CARGO SLIDES

THE SLIDE GUIDE

OnScene Solutions has a slide for every position and solution that crews demand.

81 SERIES 3-RAIL SINGLE DIRECTION

This single-direction slide extends up to 100% of its full length for easy cargo access, while the three-rail design delivers extreme cargo carrying capacity.

Extension	Capacity	Depth
100%	1,000 lbs.*	20-120"



819 SERIES SLIDING STEP

This three-rail slide mounts under the truck body and supports 500 lbs. when extended. The greasable latch combats road debris. Shown with optional NFPA tread-plate decking.

Extension	Capacity	Depth
100%	500 lbs.*	16"



82 SERIES 2-RAIL SINGLE DIRECTION

Without sacrificing weight capacity, this two-rail slide features a low-profile design perfect for compartments with lower ceiling heights.

Extension	Capacity	Depth
70%	1,000 lbs.	28-96"

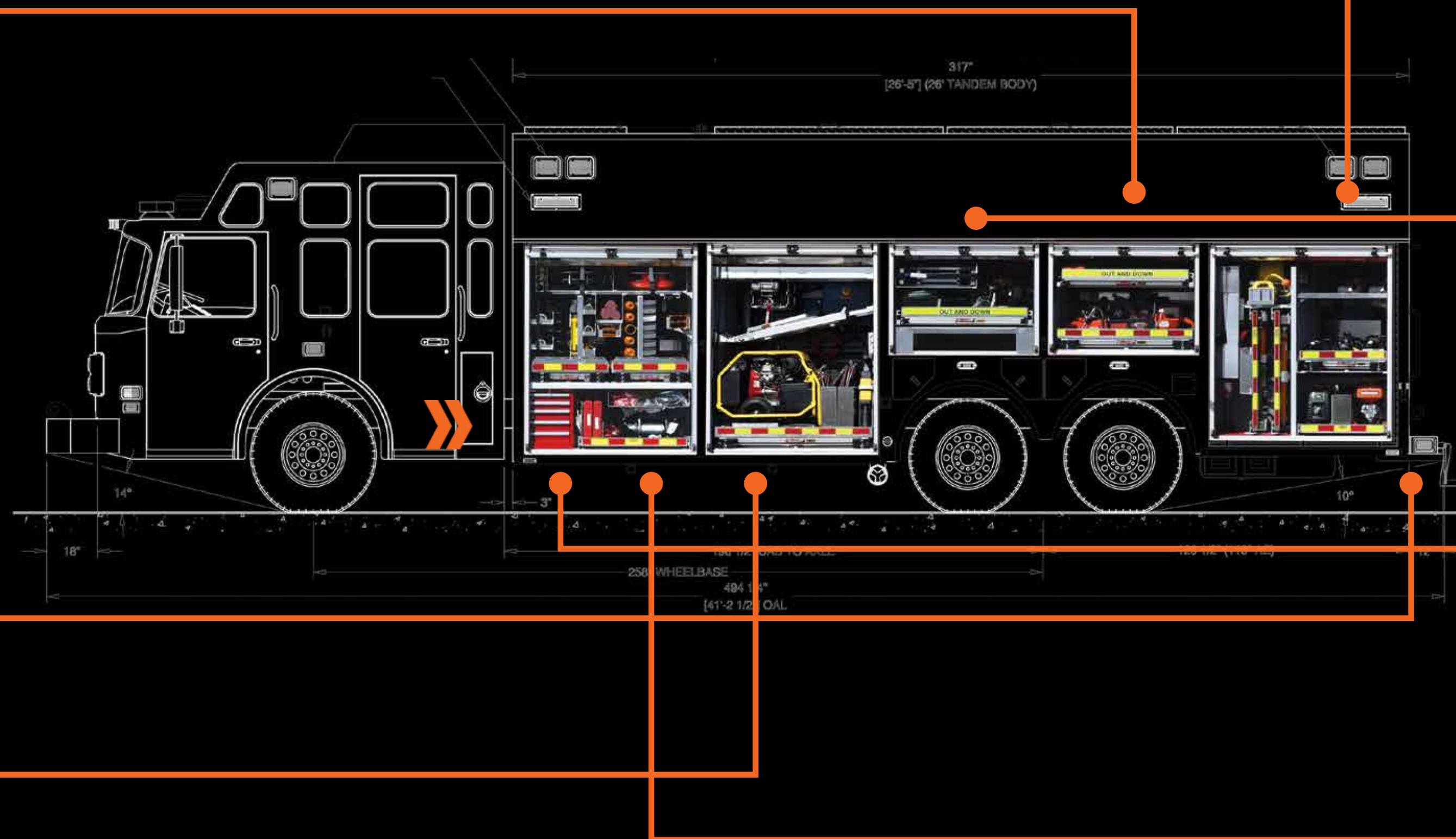

**83 SERIES / 83 900 SERIES
TRANSVERSE**
These dual-direction transverse slides are ideal for pass-through compartments, featuring up to 1,000 lbs. of capacity and 70% extension. The 83 900 features a 16" fixed width for tool boards.

Extension	Capacity	Depth
70%	1,000 lbs.	40-96"



**84 SERIES
OUT-AND-DOWN**
For easy access to high storage areas, look to the 84 Series' slide-out / tilt-down design that delivers a 30-degree access angle and up to 250 lbs. of capacity.

Extension	Capacity	Depth
100%	250 lbs.*	13"-60"



**85 SERIES
TOOL BOARD**
A clone of the 81 Series but in a narrow 11.375" design, the 85 Series accommodates tall, slim compartments, as well as vertical tool boards.

Extension	Capacity	Depth
100%	1,000 lbs.	16-120"



**86 SERIES
NON-ANODIZED**
This welded, NON-anodized aluminum slide provides an economical cargo system, featuring 100% extension. The ultra-low profile design (at 2.75") is perfect for lower compartments.

Extension	Capacity	Depth
100%	600 lbs.	16-30"

* Check technical data for de-rated lengths/widths.

CARGO SLIDES



OUR LATEST CARGO INNOVATIONS

CONFIGURABLE CARGO TRAY

Your department won't find a more versatile cargo tray than OnScene Solutions' all-new Configurable Tray with optional customizable tray separators, adjustable tie-downs and fold-down gates. Featuring a limited lifetime warranty, this corrosion-resistant anodized aluminum tray can be ordered to fit most any manufacturer cargo slide. Custom sizing is available!

1 FOLD-DOWN GATE(S)

The tray design incorporates optional front and rear fold-down gates to eliminate unnecessary heavy lifting over the tray's edge.

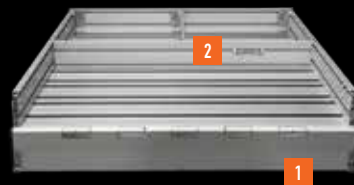

2 MOUNTING POINTS

This anodized aluminum tray features configurable mounting points in the tray sidewalls and floor slats.



3 OPTIONAL REFLECTIVE STRIPING



CONFIGURABLE CARGO TRAY

Control the scene from any side with the OnScene Solutions Transverse Tool Board, featuring a 16" fixed tool board width designed for pass-thru compartments.

Extension	Capacity	Depth
70%	1,000 lbs.	40-96"

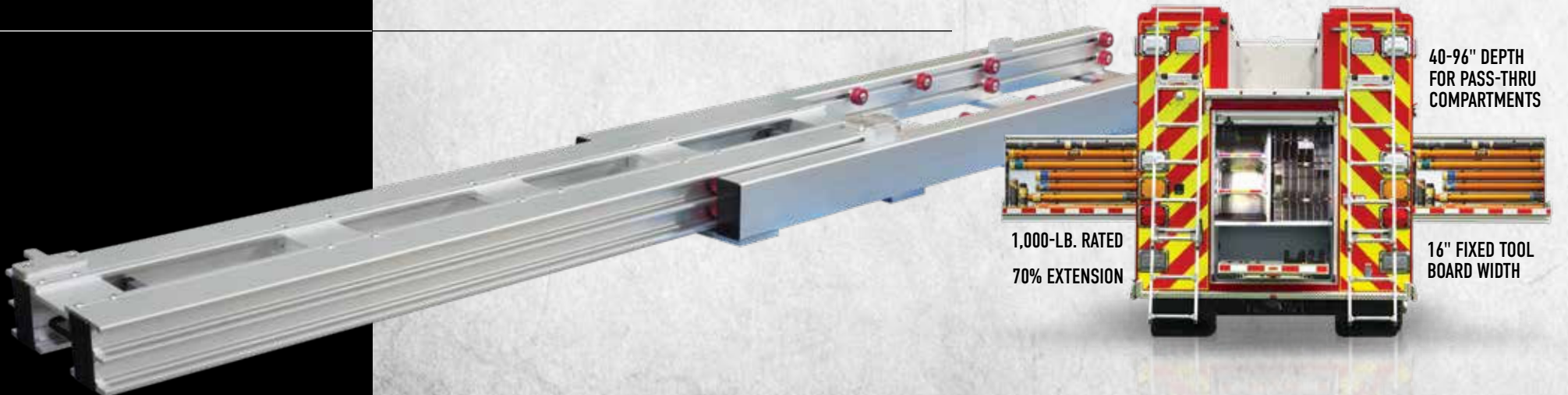

1,000-LB. RATED
70% EXTENSION

40-96" DEPTH
FOR PASS-THRU
COMPARTMENTS

16" FIXED TOOL
BOARD WIDTH

THE X-30 LIFT SYSTEM

LET US DO THE HEAVY LIFTING ...



PRODUCTION READY! ORDER YOURS TODAY.

Featuring a 500-lb. capacity and 30-36" of downward travel, the X30 cargo lift system lowers heavy equipment with the push of a button, positioning gear at the ideal height for better ergonomics.

Extension	Capacity	Depth
100%	500 lbs.	Varies

Available in various sizes.

LED LIGHTING

LIGHTING FOR ANY RESPONSE

The versatile Night Axe™ and Access LED lighting systems are adaptable to any response vehicle and mounting location. Featuring an easy-to-install, waterproof design, these systems are rated for 100,000 hours of service.



LED LIGHT COLOR OPTIONS:

ACCESS PRO COLOR OPTIONS:



ACCESS COLOR OPTIONS:



STAGNANT WHITE, BLUE OR GREEN

COLOR-CHANGING

WHITE » BLUE

WHITE » GREEN

WHITE » RED

ALSO AVAILABLE IN STAGNANT WHITE, BLUE, GREEN OR RED OPTION

LED LIGHTS + BEZELS

ACCESS PRO COMPARTMENT LIGHTING

Available in static white, blue or green, the Access Pro delivers a neon-like experience that eliminates LED hotspots without losing light output. Plus, this efficient light consumes 25% less energy than competing LED compartment lights.



Output	Warranty	VDC
400 lumens for every 18" of light	Lifetime	12

Mounting hardware included

ACCESS COMPARTMENT LIGHTING

Available in stagnant white, blue, green or red variation or OnScene's color-changing white-red, white-blue or white-green options, the Access compartment lighting system delivers an abundance of luminous output for extreme lighting situations for tight budgets.



Output	Warranty	VDC
400 lumens for every 18" of light	5 year	12 or 24

Mounting hardware included

NIGHT AXE™ COMPARTMENT LIGHTING

The industry's only linear tube lighting system to be UL/ULC certified, OnScene Solutions' premium compartment light, the Night Axe™, features PWM technology to reduce amperage draw and heat, ensuring a 100,000-hour lifespan.



Output	Warranty	VDC
200 lumens for every 18" of light	10 year	9-32 (auto sensing)

Mounting hardware included



IN-CAB LIGHTING

These red-white capable lights pull extra duty thanks to remote switching ability, a park brake interface and timed dome feature. Use as your dome, map and cab light! These low-profile lights can be surface mounted without cutting interior panels.

Output	
Dual intensity	
High-low standard	
Warranty	VDC
5 year	9-24 (auto sensing)

LIGHTING BEZELS

These lighting bezels provide attractive yet durable housings for OnScene's LED lighting. The waterproof design can mount to most any flat surface. Choose your finish in either walkway or under-cabinet angle:

- 1 Anodized aluminum
- 2 Polished cast aluminum
- 3 Ball burnished cast aluminum



Anodized aluminum: 6"-72" lengths
Cast-aluminum: 9" or 18" lengths

BUILT TO SECURE YOUR EQUIPMENT



The market's only three-point system

HELMET MOUNT

An innovative solution that meets NFPA 1901 helmet containment requirements — OnScene's patented Talon helmet mount. With multiple adjustment points, the Talon can be configured to fit nearly any helmet with a brim, including EU-style helmets.

Construction	Warranty
Anodized aluminum with stainless-steel hardware	Lifetime warranty



Glove-friendly release

Orange reflective tab for quick release

CARGO STRAPS

Featuring a quick-release buckle or a Velcro strap with orange reflective tab, OnScene's cargo straps are a favorite among on-the-go crews. These nylon straps are virtually weather proof and chemical resistant.* Each Velcro strap comes complete with mounting hardware.

Construction	Warranty
Nylon webbing strap (resistant to most chemicals)	Limited 2-year warranty

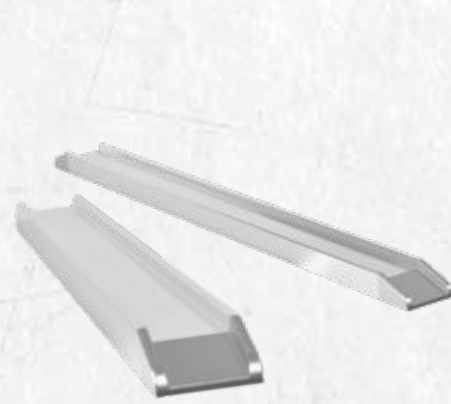

Rubber mounted to prevent unit damage

RUB RAIL

Eliminate the tedious task of manufacturing rails with these pre-manufactured rub rails, featuring a recessed design to protect optional DOT reflective tape or marker lights. Optional waterproof lights attach to the rail's rear side, directing ground lighting to the operator's feet.

Construction	Warranty
Corrosion-resistant anodized aluminum	Limited lifetime warranty



Available in different reel configurations

REEL EXTENSION

Often, Hannay hose or cord reels are mounted too far in the compartment to accommodate reeled-in spools, making access difficult. This reel extension positions the end of the hose or cord closer to the door opening, eliminating damage to equipment and door seals.

Construction	Warranty
Powder-coated aluminum	Limited lifetime warranty



Grooved channels for moist environments

HOSEBED SLATS

Lightweight yet durable, these aluminum hosebed slats can be ordered in lengths of up to 146" or can be custom cut. The slats feature channels that allow hose moisture to escape easily, while the grooved channels also provide a slip-resistant walking surface for crews.

Construction	Warranty
Cast aluminum slats in lengths of 146" or less	Limited warranty

MULTI-USE



Handle can be angled for different uses

WELLZ TOOL

You won't find a more versatile personal carry tool than the Wellz multi-function tool. This forcible entry tool, which fits into a responder's pocket, can:

- Breach doors
- Block door hinges
- Shut off gas meters
- Open fire hydrants

Construction	Warranty
High-strength 7075 anodized aluminum; teflon coated	Limited structural warranty





ONSCENE SOLUTIONS

OnSceneSolutions.com
877-567-4712
info@onscenesolutions.com



CARGO LIFT SYSTEMS



HEAVY-DUTY SLIDES



ADJUSTABLE TRAYS



LIGHTING SOLUTIONS



EQUIPMENT SECUREMENT

See your sales representative for further information and prices. All information in this catalog and on www.OnSceneSolutions.com is the latest available at the time of publication approval. OnScene Solutions reserves the right to make changes and to discontinue products without notice or obligation. Photography may show optional equipment. Printed in the USA. 500 0326 ©2026 OnScene Solutions